

extra capacity

extra service life

Datenblatt

BACS ATEX C20ex3/C30ex3/C40ex3

Zone 1 / 2

Zone 21 / 22

<p>Certified according to ATEX and IECEx</p> <p><i>Protection Type: ATEX</i></p> <p>II 2G EX db IIC T5 Gb II 2D EX tb IIIC T100°C Db</p> <p>ATEX Certificate Number: 18ATEX0119X</p> <hr/> <p><i>Protection Type IECEx</i></p> <p>EX db IIC T5 Gb</p> <p>IECEx Certificate Number: DEK 18.00.75</p>
--



ATEX / IECEx certified BACS® for EX Environment Zone 1/21 and 2/22

BACS ist das erfolgreichste und leistungsfähigste System für stationäre Batteriesysteme, alle angeschlossenen Geräte zur Stromversorgung und Sensorik in Batterie- und USV Räumen

BACS® ist das sicherste Batterie Management System am Markt, welches zusätzlich die umgebende Infrastruktur überwachen und verwalten kann. BACS® beginnt bei Messergebnissen aus dem direkten Umfeld einer Batterie wie Spannung, Impedanz, Temperatur, Luftfeuchtigkeit, Säurefüllstand, Wasserstoffgaskonzentration, Druck, etc. BACS® kann bei Bedarf zusätzlich auch die Kontrolle über externe Hardware wie komplexe Klimakontrollsysteme und Notentlüftung übernehmen. Selbst Sensoren und Kontakte zu und von Systemen von Drittanbietern kann BACS® zuverlässig verwalten und sich damit in Brandmeldesysteme integrieren. BACS verfügt zudem über eine Schnittstelle für alle Arten von USVs, Wechselrichtern, Übertragungsschaltern, Generatoren und anderen Geräten, die von Batterien betrieben werden. Abgerundet kann BACS® kann sich transparent in alle Arten von Netzwerkstrukturen wie BACnet, SNMP oder MODBUS und optional auch in andere Feldbusse einfügen und an bestehenden Sicherheitsrichtlinien anpassen.

BACS behält auch in einer komplexen Notfallsituationen den Überblick.

Ähnlich wie eine speicherprogrammierbare Steuerung (SPS) kann BACS® (und der CS141) für die Verwaltung von automatischen Notfallprozeduren programmiert werden. Kernfunktionen bilden hier unter anderem die Verwaltung der Geräte von Drittanbietern (andere USV SNMP Karten oder andere Sensoren), aktives Notfallmanagement vor Ort sowie ein umfangreiches Notfallbenachrichtigungssystem, mit dem alle erforderlichen Informationen bei Bedarf unmittelbar bereitgestellt werden, damit Krisenreaktionsteams schnellstmöglich reagieren können.

BACS liefert eine verbesserte Wirtschaftlichkeit und Sicherheit und ist kein „Luxus“ wie andere Battery Monitoring Systeme – dies liegt zum großen Teil am „Balancing“:

Um das Ladeverhalten zu optimieren, setzt BACS® auf unser selbst entwickeltes passives Regelverfahren - in Europa als „Equalizing“ und weltweit als „Balancing“ bekannt. Damit kann die Ladespannung aller Batterien innerhalb der optimalen Werte, die der Akkuhersteller spezifiziert, gehalten werden. **Diese Regelung hat massiven Einfluss auf das Verhalten der Batterien und damit auf die Kosten und Zuverlässigkeit der gesamten Anlage.**

Die Lebensdauer aller Batterien ist das Kostspielige bei jeder batteriegestützten USV-Lösung: Fällt eine Batterie aus, dann müssen in der Regel **alle** Batterien getauscht werden. Die Lebensdauer eines solchen Batterieverbands in einer USV liegt bei 50-60% des angegebenen Design Life von Batterieherstellern. Diese inakzeptabel kurze Lebensdauer kann durch das Equalizing/Balancing enorm verbessert werden. Mit dieser Technik wird jede einzelne Batterie auf dem optimalen Spannungsniveau gehalten, um eine Überladung oder Unterladung zu vermeiden. Der Hauptgrund für vorzeitigen Ausfall von Akkus in stationären Anlagen fällt damit weg. Das dies zusätzlich eine Verbesserung in der Kapazität einer Batterieanlage hat, ist ein willkommener Nebeneffekt, und nachweisbar: Kapazitätsmessungen von Endkunden haben gezeigt, dass Anlagen, die BACS verwenden, gegenüber Vergleichsanlagen ohne BACS Batterien um **bis zu 20% höhere Kapazität** aufweisen. Der Grund hierfür ist einfach erklärt: Akkus, die nicht unterladen sind, erreichen 100% Kapazität und stellen bei einem Kapazitätstest diese erhöhte Leistung nun zur Verfügung.

Mit BACS® wird nachweislich die Gebrauchsdauer aller Batterien in Hochspannungs-String-Anwendungen verlängert, so dass das angegebene Design Life tatsächlich erreicht werden kann. Etwas, das kein Battery Monitoring System leisten kann. Ein Monitoring System kann nur Daten anzeigen, und hat keinen wirtschaftlichen Effekt und ist daher ein reiner „Luxus“, der die tatsächlichen Kosten erhöht – ohne ein Plus an Sicherheit oder eine Verbesserung der Kosten.

BACS® kann in jedes Netzwerk integriert werden, und sammelt selbstständig alle betriebsrelevanten, Spannung, Temperatur, Innenwiderstand, etc. Zusätzlich kann BACS® das individuelle Ladeverhalten für jeder Batterie oder sogar jeder Zelle innerhalb eines Batteriestrangs von USV-Speichersystemen aktiv regeln und **die Kapazität ermitteln**. Wo andere Systeme mühevoll kumulieren und auf- bzw. abrunden oder schätzen müssen, kann BACS wegen Balancing eine bessere Rechengrundlage einsetzen und so gleichwertige Kapazitätsmessungen erreichen ohne aufwendige zusätzliche Messtechnik. BACS ist das ideale System für alle Arten von Blei/NiCd-Säure-Batterien (offene / nasse Zellen, wartungsfrei, Gel, AGM usw.) und auch für die meisten Arten von Li-Ionen-Batterien.

ATEX / Eigensicherheit im Regelbetrieb

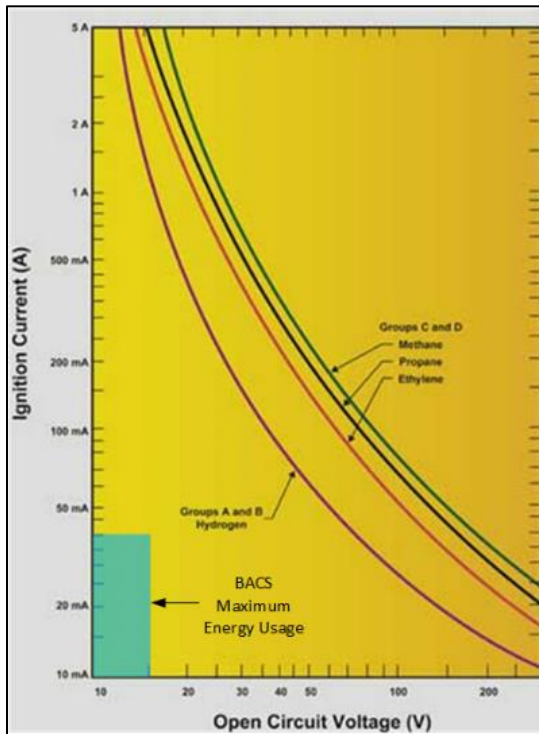

Die Öl- und Gasindustrie besteht auf Grund sehr hoher Sicherheitsvorschriften auf besondere Schutzvorkehrungen gegen Funkenflug oder Überhitzung, sobald IT-nahe Systeme innerhalb des Gefahrenbereichs potentiell hochexplosiver Gase betrieben werden müssen. Da einige dieser Systeme im Notfall nicht ausfallen dürfen, kommen zur Absicherung oft USV-Lösungen für die Notstromversorgung zum Einsatz.

Ein Batteriemangement System im EX-Bereich (Explosionsgeschütztem Bereich) soll daher – ebenso wie die USV - eine Zertifizierung gemäß ATEX nachweisen können, um in solchen Umgebungen betrieben werden zu dürfen. **Ein solches ATEX-Zertifikat ist allerdings gar nicht erreichbar sobald eine Batterie eingesetzt wird – weil eine Batterie als Wasserstoff Quelle gar nicht im EX Bereich eingesetzt werden darf da diese bei einem Kurzschluss in jedem Fall einen Funken oder sogar Lichtbogen erzeugen kann.** D.h. obwohl ein Batteriesensor ATEX geprüft sein mag, verfällt die Gültigkeit sobald der Sensor auf eine Batterie aufgebracht wird die selbst nicht ATEX sicher sein kann. Diese Absurdität ist vielen Anwendern nicht klar und man beharrt auf ein Zertifikat für die Batteriesensoren obwohl dieses eigentlich automatisch verfällt sobald es auf Akkus eingesetzt wird.

Aus dem Grund gehen wir mit einem anderen Ansatz an die Problematik heran: Wir bezeichnen unseren BACS Sensor als „Eigensicher“ – weil das Potenzial für die Erzeugung eines Funkens das Gas zum Entzünden bringen kann bei unserem System nicht anliegen kann. Die Zeichnung oben links zeigt die für die jeweilige Gasgruppe zulässigen Ströme und Spannungen wo es zu Explosion kommen kann. Alle Geräte, die unterhalb der jeweiligen Kurve liegen, sind als „Eigensicher“ zu sehen. BACS liegt deutlich unterhalb dieses kritischen Bereichs und es ist damit im Normalbetrieb nicht möglich, einen Zündfunken zu erzeugen der zu einer Explosion führen könnte.

Der BACS-Viewer – Professionelles Batteriedatenauswertung

Die BACS® VIEWER-Software kann mehr als nur Daten aus dem Manager abrufen und so den lokalen Speicher eine BACS WEBMANAGERs für die „Ewigkeit“ sichern.

Die BACS® VIEWER-Software ist ein leistungsstarkes Programm zur Analyse und Archivierung von Batteriedaten eines BACS Systems. Es integriert zusätzliche Dokumente wie Zeichnungen, Berichte, Garantiezertifikate, Wartungspläne, Handzettel für technisches Personal und erleichtert die Verwaltung von vielen BACS Systemen und damit tausenden von Akkus mit einer zentralen Software. Mit der BACS® VIEWER-Software können Wartungsarbeiten festgelegt werden, Batterietrends ermittelt werden, fehlerhafte Akkus werden erkannt und Statusberichte werden automatisch erzeugt.

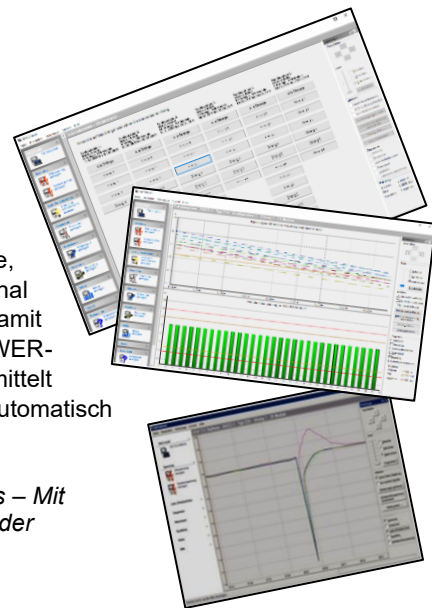

Unregelmäßigkeiten in der Batteriechemie sind Vorboten eines Problems – Mit BACS gehört die Grauzone „Batterie“ für systemkritische Anwendungen der Vergangenheit an!

Beispiel: Aufspüren einer defekten Batterie

Der BACS® VIEWER zeigt die individuelle Batteriespannung aller Akkus am Ende einer Entladung mit der rot gepunkteten senkrechten Linie an. Das Balkendiagramm zeigt Auflistung aller Akkumulatoren zu dem Zeitpunkt an und markiert die Akkus, die früh zusammengebrochen sind und auf ein sehr niedriges Niveau entladen wurden. Diese markierten Batterien stellen ein potenzielles Risiko für die Systemintegrität dar und sollten geprüft werden.

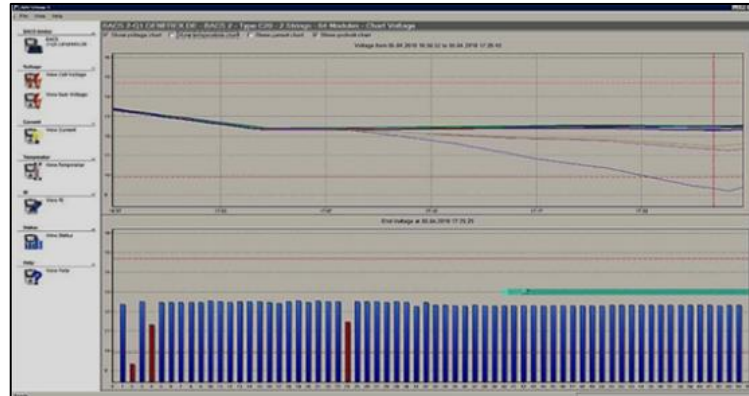

Mit dem BACS VIEWER ist es möglich beschädigte Batterien zu erkennen und auszutauschen - ohne das diese geschädigten Akkus andere, noch gesunde Akkus in Mitleidenschaft ziehen und später ebenfalls getauscht werden müssen.

Aufbau des ATEX BACS Gehäuse

Das ATEX BACS Gehäuse unterscheidet sich von der klassischen BACS Installation. Die Hauptunterschiede sind ein externer Temperaturfühler, der im BACS Messkabel integriert ist, im Gehäuse integrierte Sicherungen sowie 3 Module pro Gehäuse.

1. Anschlusskabel BACS Bus Diese Verbindungskabel dienen der BACS Buskommunikation mit dem benachbarten BACS ATEX Modul (bzw. zum BACS WEBMANAGER / SPLIT-TINGBOX welcher sich in der Regel außerhalb des explosionsgefährdeten Bereichs befindet) .Die Buskabel werden entweder vor Ort auf die gewünschte Länge vom Installateur konfektio-niert, oder können in unterschiedlichen Längen vorkonfektionert bestellt werden. Die Kabel müssen vom Installateur durch die Schraubklemme (2) geführt und durch Anziehen der Schraube abgedichtet werden.

2.ATEX-Kabelverschraubungsklemme mit Dichtung: Nachdem Sie das BACS Bus Kabel eingeführt haben, ziehen Sie die Schraubklemme zu – die integrierte Dichtung wird sich um das Kabel legen und so gasdicht versiegeln.

3. Kabel zum Plus Pol des Akkus (ROT) : Damit wird der erste der 3 positiven Batteriepole verbunden. Die anderen verbliebenen roten Messkabel werden zur 2ten und 3ten Batterie an den Pluspol gelegt. Die Roten Leitungen sind individuell anpassbar und können vom Installateur auf die gewünschte Länge gekürzt und mit neuen Kabelschuhen versehen werden.

4. Kabelverbinder Minus Pol (Schwarz): Damit wird der erste der 3 negativen Batteriepole verbunden. Die anderen verbliebenen schwarzen Messkabel werden zur 2ten und 3ten Batterie an den Minus pol gelegt. Diese Kabel sind geringfügig dicker als die roten Pluskabel, weil hier im Kabelschuh ein Temperatursensor verarbeitet worden ist.

5. Sicherung BACS-Modul: Die 2 zu jedem BACS Modul gehörigen Sicherungen befinden sich auf der Hauptplatine und können bei Bedarf ausgetauscht werden.

6. BACS Modul : Jedes C20ex3xxxx kann bis zu 3 BACS Module aufnehmen. Jedes BACS Module ist mit einem BACS Buskabel (als Flachbandkabel) verbunden und jeweils das 1ster und das 3te Modul wird über die BACS Buskabel und die Schraubklemme mit dem nächsten BACS ATEX Gehäuse verbunden (bzw. mit dem BACS WEBMANAGER oder SPLITTINGBOX ausserhalb des Explosionsgefährdeten Bereichs) Jedes BACS Modul hat bei Auslieferung die Identnummer ID 0 – dieses muss noch konfiguriert werden.

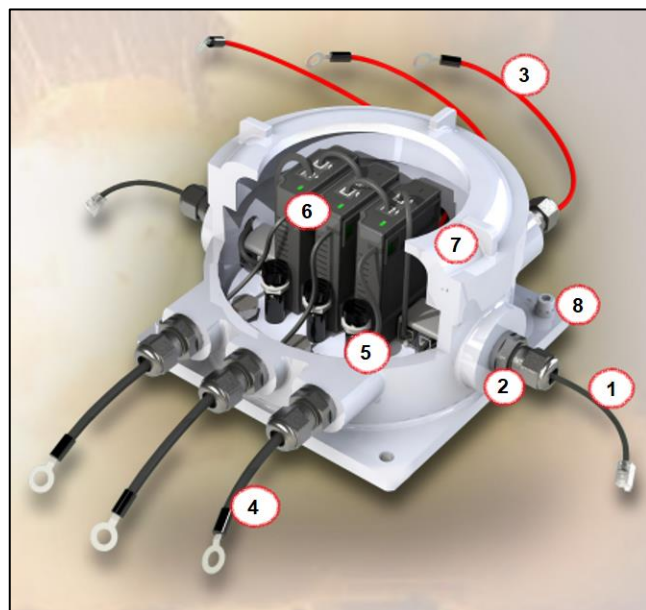



ATEX / IECEx certified BACS® for EX Environment Zone 1/21 and 2/22

7. Schraubdeckel mit Sichtfenster: Wenn die Adressierung und Verkabelung abgeschlossen wurde kann der Schraubdeckel geschlossen werden und die Arretierungsschraube angezogen werden. Damit ist das Gehäuse bereit für den Einsatz innerhalb der ATEX-Zone 1 und 2 und kann in Betrieb genommen werden.

8. Montagelöcher für die stationäre Anbringung und Erdung: An diesen 4 Montagelöchern kann das BACS Modul am Batterierack, Wand oder an anderer Stelle befestigt und geerdet werden.

Technische Daten: ATEX Gehäuse und Gehäuseversionen:

Beachten Sie unbedingt die Vorschriften und Zeichnungen für die ATEX-Zone 1/2 bzw. 21/22. Das Gehäuse darf nicht in der Zone 0 bzw. 20 angebracht werden. Achten Sie auf Ausreichend Abstand zu der entsprechenden Gefahrenzone. Nutzen Sie die Schraublöcher (8), um das Gehäuse vor Ort permanent zu befestigen und zu fixieren, um einen stabilen Aufbau zu garantieren.

Gehäuse: TBE 160TW

Alle Angaben in mm / metrisch

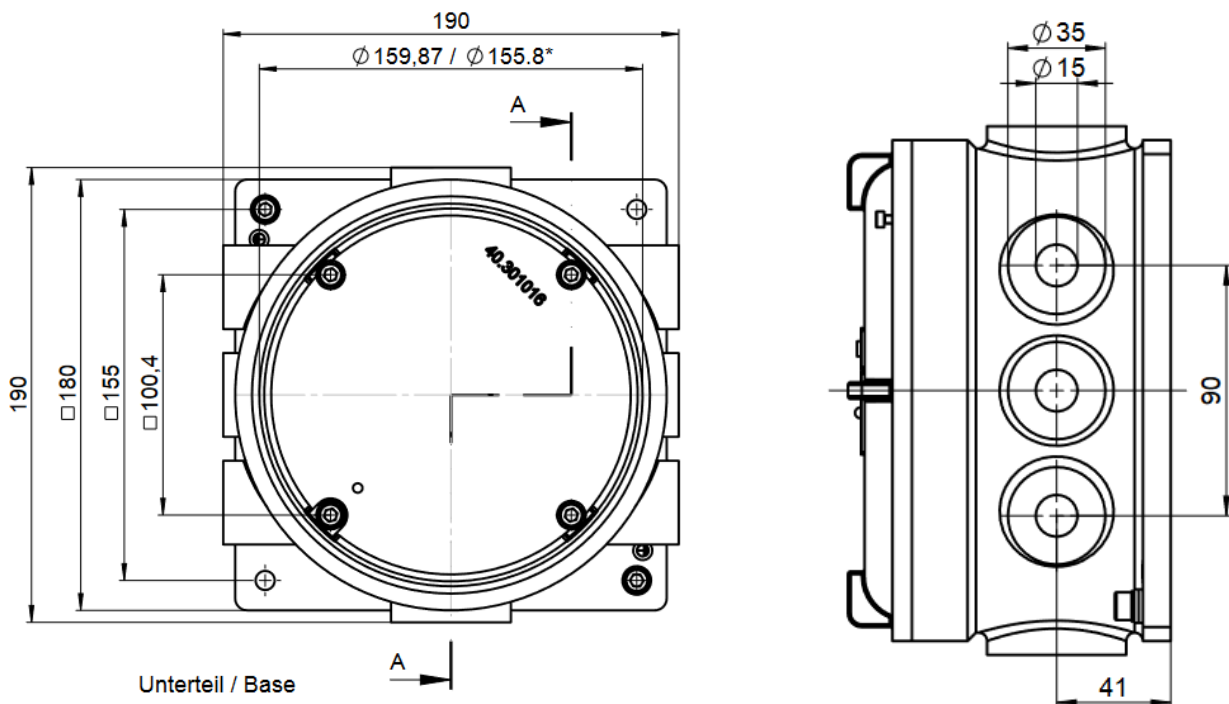

Gewicht: 3,9 kg

Maße: 300mm * 300mm * 140mm, gemessen inkl. Kabelverschraubung und Schutzkappe

<p>ROSE Systemtechnik GmbH D-32457 Porta Westfalica</p>	<p>2004</p>	<p>Ex db IIC T5 Gb -20°C ≤ Ta ≤ +55°C</p>
	<p>Type: TBE 160TW 41 W IP66 DD.MM.YY 00000000</p>	<p>DEKRA 18ATEX0119X IECEx DEK 18.0075S WARNING - DO NOT OPEN WHEN ENERGIZED</p>

Mehrere Erdungspunkte

Leicht zugängliche Erdungspunkte ermöglichen eine umfangreiche Erdung, um elektrostatische Entladung effektiv zu verhindern.

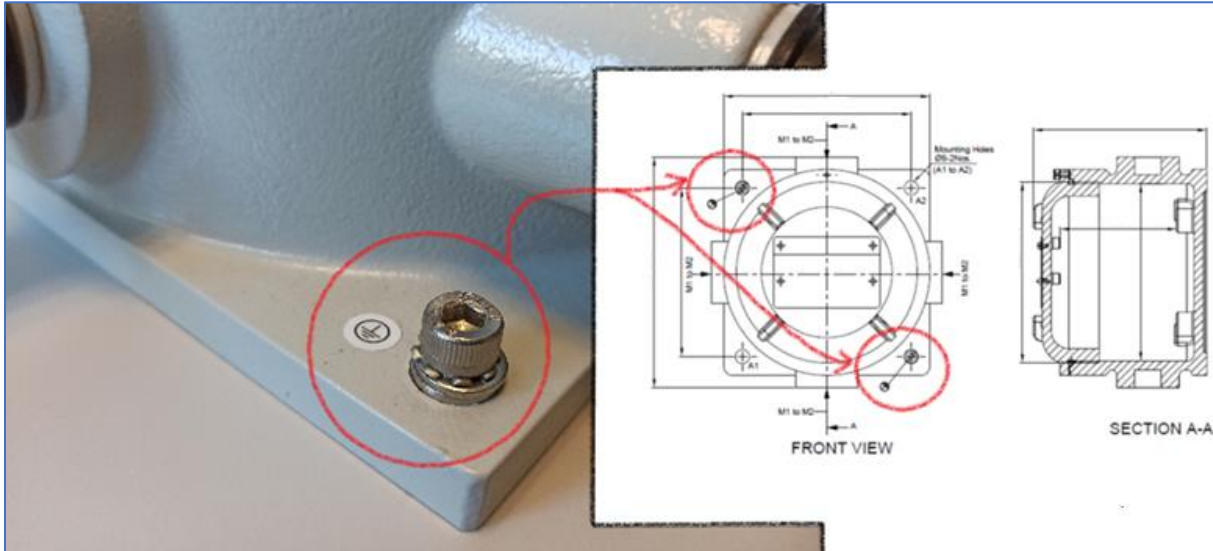

Sealing gem. ATEX / EX-i

Jeder Ein- und Ausgang ist individuell gemäß EX-i und ATEX speziell gesichert und versiegelt

	<ul style="list-style-type: none"> a. RJ12 Stecker b. Sockelschraube c. Dichtungsring der Spannschraube d. Spannschraube für die Dichtung e. Schutzkappe (Berührungsschutz) f. Dichtungsring zur Montage der Sockelschraube
--	---

Factory pre-assembled cables

Vorkonfektionierte Kabel haben den Vorteil, dass die Dichtungen bereits eingebaut sind. Diese Kabel können direkt am Gehäuse montiert werden. Die BACS-Buskabel für die Verbindung zwischen zwei Gehäusen verfügen an beiden Kabelenden vor dem Stecker über eine vorinstallierte Dichtung.





ATEX / IECEx certified BACS® for EX Environment Zone 1/21 and 2/22

Blindstopfen

Alle nicht verwendeten Ausgänge können mit den beigelegten Blindstopfen ATEX-Konform versiegelt werden.





ATEX / IECEx certified BACS® for EX Environment Zone 1/21 and 2/22

Technical data





General technical data: CS141 / BACS HW161 Webmanager Product family



CS141 PRODUCT SERIES GENERAL OPERATING DATA	
Processor and memory	ARM Cortex A8 800MHz CPU, 8GB storage for battery history.
Operating condition	Temperature 0 - 60°C, max. humidity 0 - 90%, non-condensing
MTBF (calculated)	849192 hours; 96,9 years
corresponds to RAL 7035 Power consumption	At 12V default power supply consumption approx. 150mA. Note: At BACS a CONVERTER is included.
MTBF (calculated)	849192 hours; 96,9 years
maximierenDisplay	2x LED (Manager status, UPS/device alarm)
External BACS kit CS141 housing	ABS, corresponds to RAL 7035 (light grey) CE, UL 94/NEMKO certified flame retardant
SLOT BACS kit CS141 housing	Slot card "SC format" for UPS devices witch compatible slots UL- Certification
BACS Webmanager Budget housing	Aluminum, RAL 7035 (light gray) UL/NEMKO certificated – or – ABS 94/NEMKO certified flame retardant with integrated DIN Rail
Number of possible BACS modules	The Standard Power supply (2000 mA) grants power for up to 360 BACS C modules. For up to 512 modules and sensors, ask for larger power supply.
Operation altitude range	0m – 4000m
Operating maintenance	Removal of dust and dirt in regular terms is required, beside this, the BACS WEBMANAGER, measuring cables and the BACS modules do not need any maintenance work. There is no internal battery used that need maintenance or replacement.
BACS GENERAL STORAGE DATA	
Temperature range	-55°C – 70°C
Humidity range	0% -90% in non condensing environments
Storage altitude range	0m – 4000m
Particular additional information	Open storage in heavily sooty or dusky storage conditions or environments with sediment deposits can have a negative effect. Acidic or similar aggressive atmospheric environmental conditions may also affect long-term storage
Storage Maintenance	The BACS WEBMANAGER, measuring cables and the BACS modules do not need any maintenance work during storage. There is no internal battery used that need maintenance or replacement

ATEX / IECEx certified BACS® for EX Environment Zone 1/21 and 2/22



BACS kit product bundle differences to general data:

 <p>CLN us 60950</p> <p>CE UK CA</p> <p>BACS® WEBMANAGER BUDGET SC (slot version) Order No. BACSKIT_BSC4</p> <p>Interfaces</p>	<p>3x RS-232 interfaces, (COM1= UPS/power device, COM2 =Multipurpose, COM3=BACS battery bus) 1x RJ12 for battery bus converter 1x RJ45, 10/100Mbit Ethernet</p>
 <p>CLN us 60950</p> <p>CE UK CA</p> <p>BACS® WEBMANAGER BUDGET SC MINI (Mini Slot Version) Order No. BACSKIT_BSC4</p> <p>Interfaces</p>	<p>1x RJ12 Multiport for accessories and battery bus converter 1x Spitting Port cable for simultaneous use</p> <p>1x RJ45, 10/100/ 1000Mbit Ethernet</p>
 <p>CLN us 60950</p> <p>CE UK CA</p> <p>BACS® WEBMANAGER BUDGET L Order No. BACSKIT_LB4</p> <p>Interfaces</p>	<p>3x RS-232 interfaces, (COM1= UPS/power device, COM2 =Multipurpose, COM3=BACS battery bus) 1x RJ12 for battery bus converter 1x RJ45, 10/100/ 1000Mbit Ethernet</p>
 <p>CLN us 60950</p> <p>CE UK CA</p> <p>BACS® WEBMANAGER BUDGET SCM RS485 (slot version) Order No. BACSKIT_SCMB4</p> <p>Interfaces</p>	<p>2x RS-232 interfaces, (COM1= UPS/power device, COM3=BACS battery bus), 1 * RS485 = COM2 1x RJ12 for battery bus converter 1x RJ45, 10/100/ 1000Mbit Ethernet</p>
 <p>CLN us 60950</p> <p>CE UK CA</p> <p>BACS® WEBMANAGER BUDGET LM RS485 Order No. BACSKIT_LMB4</p> <p>Interfaces</p>	<p>2x RS-232 interfaces, (COM1= UPS/power device, COM3=BACS battery bus), 1x RS485 1x RJ12 for battery bus converter 1x RJ45, 10/100/ 1000Mbit Ethernet</p>



ATEX / IECEx certified BACS® for EX Environment Zone 1/21 and 2/22

BACS WEBMANAGER BUDGET differences to general data:

	<p>BACS® WEBMANAGER BUDGET - 12V Order No. BACSKIT_B4</p>	
	<p>Interfaces</p>	<p>3x RS-232 interfaces, (COM1= UPS/power device, COM2 =Multipurpose, service port for Windows BACS READER and PROGRAMMER software) USB 2x battery bus converter outputs internal 1x RJ45, 10/100Mbit Ethernet 1x potential-free contact (2 pole screw wire size 1,0 mm², rated load 24 VDC /1A</p>
<p>Dimension Weight</p>	<p>Dimension Weight</p>	<p>130 x125 x 30mm = 5,12 x 4,92 x 1,18 in. (W x L x H) Aluminium 360g / ABS housing 238g</p>
	<p>BACS® WEBMANAGER BUDGET - 18V-72V Order No. BACSKIT_B4</p>	
 	<p>Interfaces</p>	<p>3x RS-232 interfaces, (COM1= UPS/power device, COM2 =Multipurpose, service port for Windows BACS READER and PROGRAMMER software) USB 2x battery bus converter outputs internal 1x RJ45, 10/100Mbit Ethernet 1x potential-free contact (2 pole screw wire size 1,0 mm², rated load 24 VDC /1A</p> <p>130 x125 x 30mm = 5,12 x 4,92 x 1,18 in. (W x L x H) Aluminium 360g / ABS housing 238g</p> <p>Technical data: TRACOPOWER TCL 024-112DC</p> <p>Input Output Notes</p> <p>18V – 72V DC 12V 2000mA DC stabilized up to 390 BACS Modules Input safeguarding fuse (recommended circuit breaker 6-16A / characteristic C) is not included.</p>
	<p>BACS® WEBMANAGER BUDGET - 90V-375V Order No. BACSKIT_B4_375</p>	
 	<p>Interfaces</p>	<p>3x RS-232 interfaces, (COM1= UPS/power device, COM2 =Multipurpose, service port for Windows BACS READER and PROGRAMMER software) USB 2x battery bus converter outputs internal 1x RJ45, 10/100Mbit Ethernet 1x potential-free contact (2 pole screw wire size 1,0 mm², rated load 24 VDC /1A</p> <p>130 x125 x 30mm = 5,12 x 4,92 x 1,18 in. (W x L x H) Aluminium 360g / ABS housing 238g</p> <p>The power supply provides 1960mA are for up to 392 BACS C modules and other BACS components.</p> <p>Technical data: TRACOPOWER TPCL 030-112DC</p> <p>Input Output Notes</p> <p>90 – 375V VDC or 85 - 264VAC 12V 2200mA DC stabilized up to 390 BACS Modules Input safeguarding fuse (recommended circuit breaker 6-16A / characteristic C) is not included.</p>



ATEX / IECEx certified BACS® for EX Environment Zone 1/21 and 2/22

In 2022, also available: The BACS Kit "LC" (Low Cost)

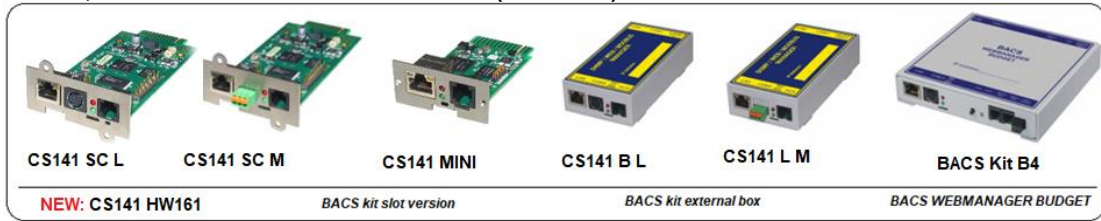

- **Special Design for smaller systems with up to 6 KVA**
 - o Prepare your UPS / SOLAR system for the next generation battery management
 - o Simply Start managing your batteries how it ever should be done
 - o No hidden "pay-per use" for new functions.
- **Benefit from all BACS features for up to 24 batteries**
 - o Use all professional BACS features
 - o Benefit from the advanced technical support
 - o Use all professional modules available for BACS
- **Scalable by design:**
 - o No new basic hardware required
 - o Use the upgrade capabilities to expand your system as needed
 - o Just enter a serial key unlock the full UPS list

As "LC" available products:

Order No	Product is identical to	Limitation overview
BACS WEBMANAGER B4LC	BACSKIT B4	<ul style="list-style-type: none"> - Up to 24 batteries - Up to 6 KVA Ups
BACS WEBMANAGER CS141 BSC4LC	BACSKIT_BSC4	
BACS WEBMANAGER CS141 BL4LC	BACSKIT_BL4	
BACS WEBMANAGER CS141SCMB4LC	BACSKIT_SCMB4	
BACS WEBMANAGER CS141SCMB4LC with RS485	BACSKIT_SCMB4 / RS485	
BACS WEBMANAGER CS141LMB4LC with RS485	BACSKIT_LMB4 / RS485	
LICENCE Upgrades		
BACSCSLCUPG	<i>License: Converts all LC Editions into a fully qualified BACS system</i>	<ul style="list-style-type: none"> - Unlocks all limitations - Software License key

BACS All-In-One - Solution:





	
<p>SITEMANAGER 6 Order No. SITEMAN_6</p>	
Processor and memory	ARM Cortex A8 800MHz CPU, 30 MB storage for battery history Non-volatile memory for alarm notification after power loss
Power consumption	40 watts max.
Interface	RS-485 interface for other devices / Adapter for RS232 support
Inputs	8 digital inputs (opened / closed configurable) 8 analog inputs (0 - 10V, 4 - 20mA, 0 - 20mA configurable via jumpers) 2 x RJ10 for BACS battery bus
Outputs	8 relay outputs (changer, max. 230V/ 4A AC/DC)
Network	10/ 100/ 1000Mbit LAN



ATEX / IECEx certified BACS® for EX Environment Zone 1/21 and 2/22





Supported protocols	Email, HTTP/HTTPs, SNMP, SNTP, MODBUS Over IP, BACnet, UPSTCP, DHCP, DNS, sFTP
Front Display	LED alarm display, LED operating status display
Dimensions	483 x 162 x 44mm, (483 x 212 x 44mm incl. SM_LOOM) 19,00 x 6,38 x 1,73in, (19,02 x 8,35 x 1,73in incl. SM_LOOM)
Weight	2262 g
Operating condition	Temperature 0 - 70°C, max. humidity 20 - 95%, not condensing
Network management	UNMS II Network Management software
Network Adapter	Optional PROFIBUS, LONBUS adapter
Additional sensors	Smoke/fire alarms, motion detectors, door contacts etc., connection of any other alarm contact indicator, which output signal is between 0 - 10V,4 -20mA or rather 0 - 20mA (configurable via jumpers)
Actuators	flash light, alarm buzzer, relay-switches, external switches, etc.

BACS Accessories

		<p>BACS® BUS CONVERTER 5 Order No. BACS_BUS_CONV_V</p>	
	Construction	Conversion and galvanic separation of the BACS battery bus to the BACS WEBMANAGER BUDGET plus real time clock (RTC) timer for the BACS WEBMANAGER.	
	Power Supply	Stabilized external 12V/2000mA	
	Number of modules	Standard Power supply grants power for up to 360 BACS C modules. For up to 512 Modules and sensors, a larger power supply is available.	
	Interface	2x RJ10 for BACS battery bus 1xRJ12 for COM3 BACS WEBMANGER BUDGET 1xMiniDin8/RS232 interface for serial connection to workstation. 1x2,1mm DC connector socket for power supply via external power supply 1x potential-free contact (2 pole screw terminals for 1,0 mm ² /24 VDC /1A)	
	Display	Optical display (LED)	
	Alarm	Internal alarm buzzer with acknowledge button	
	Housing	Polystyrene	
	Optional parts	Optional: Adapter from mini-8 to RS232 for the BACS Reader, with junction cable mini-8 1.5m	
	Dimension	91,5 x 67 x 25 (W x H x D)	
Weight	120g		
		<p>BACS® SPLITTING BOX Order No. BCII_SPLITT</p>	
	Construction	Passive splitter for BACS communication cables, designed to optimize the overall cable lengths and to create an optical pleasant wiring. In addition to the extension of the 2 BACS bus inputs of the BACS CONVERTER.	
	Power supply	Passive element, no additional power supply required	
	Interfaces	5* RJ10 for BACS bus cables 1x RJ10 input connector for BACS bus data input	
	Housing	Polystyrene	
	Dimension	91,5 x 67 x 25 (B x H x T)	
Weight	90g		
<p>BACS® DC current sensor 50/200/400/1000/2000 Ampere</p>			



ATEX / IECEx certified BACS® for EX Environment Zone 1/21 and 2/22



		BACS® bus interface GX_R_AUX Order No. GX_R_AUX		
	Description	Input alarms and Output relay management. A typical application is the control of a battery breaker in case of "thermal runaway" alarm in the battery system. Applies to US Norm International Fire Code IFC 608.3 for isolating UPS batteries in case of a thermal runaway. In case of a high battery temperature and increasing voltages during float charge, the GX_R_AUX may open the battery breaker to stop a further increase of the temperatures in the batteries. Individual programming of the relays through web interface.		
	Inputs			4 digital inputs (configurable NO/NC)
	Outputs			4 Relay potential-free outputs (NO/NC) / 50VAC – 2A, 30VDC – 1A
	Power supply			Powered by BACS bus, no external power supply
	Power consumption			170mA
	Housing			Polyamide, pluggable system DIN rail
	Dimension			75 x 75 x 45mm = 2,95 x 2,95 x 1,77 in. (LxWxH)
Weight	170g			
		BACS® CSH Current Sensor Ord. No: BACS_CSH50, BACS_CSH200, BACS_CSH400, BACS_CSH1000, BACS_CSH2000		
	Construction	DC current sensor for measuring battery string discharge and charging process +/-50A, +/-200A, +/-400A, +/-1000A, +/-2000A DC Current transducer diameter hole: 21mm [0,82in] (BACS_CSH50) /40 mm [1.57in]		
	Power supply			Intern powered by BACS bus
	Power consumption			60mA
	Interfaces			2x RJ10 for BACS bus cable, pluggable system
	Housing			DIN Rail
	Dimension (LxWxH)			110 x 82 x 125 mm = 4,33 x 3,22 x 4,92 in. (LxWxH)
Weight	420g			



ATEX / IECEx certified BACS® for EX Environment Zone 1/21 and 2/22

Modules and cables

General BACS module data

		BACS® modules Generation 3
	Construction	Measuring modules with passive balancing/equalization BACS is a registered and protected trade mark
	current consumption from battery	normal operation: 15 - 20mA (C20, C23, C30) 35 - 40mA (C40, C41) "Sleep Mode": < 1mA
	Measuring precision	Internal resistance: < 10 % at C40, < 5% at C20/30 Voltage: < 0,5 % Temperature: < 15 %
	Interfaces	2x RJ10 for BACS battery bus Internal RS232 bus interface 1x button for the addressing Temperature sensor -35 bis + 85 °C Optical display LED (alarms red/green, mode red/green)
	Housing	ABS housing (UL certified, flame retardant, cooling fins)
	Dimensions, weight	55 x 80 x 24 mm = 2,17 x 3,15 x 0,94 in. (B x H x T), 45g
	Operating condition	Temperature 0 - 60°C, max. humidity 90%, not condensing
	Int. protection rating	IP 42 coated against dust and condensate
	High voltages security tested	Protection against high ohmic batteries fault voltages up to 150 Volt /per module (fuse opens). At higher voltages the fuse opens, but BACS module is damaged. All REV 3.1 modules are designed for fault voltages up to 1000 Volt
	MTBF (calculated)	87.600 hours (10 years)

Available BACS Housings for Zone 1/ 2 and 21/22

ATEX-certified housing containing: 3 BACS C Modules for various voltages and 6 fuses inside the EX-housing. Including 6 * ATEX Halogen-free BC4/5 measuring cables, each 1.5m in length and in various ring terminal options. Including 3 * integrated temperature sensors mounted within in the negative leads.

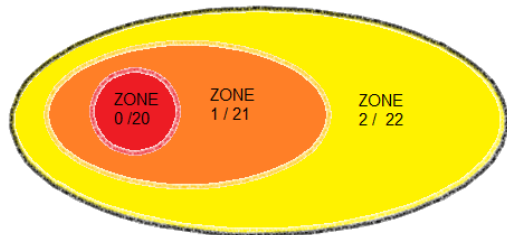

Definition of ATEX Zones



An area in which an explosive atmosphere is present continuously or for long periods of time, consisting of a mixture of air and flammable substances in the form of dust particles, gas, vapor, or mist.



An area in which it is entirely possible that an explosive atmosphere consisting of a mixture of air and flammable substances in the form of dust particles, gas, vapor, or mist could arise for a short time due to production-related reasons during normal operation - for example, when filling and emptying a system.





An area in which it is not expected that an explosive atmosphere consisting of a mixture of air and flammable substances in the form of dust particles, gas, vapor, or mist will occur during normal operation, and if it does, it will only be rare and short-lived.



ATEX / IECEx certified BACS® for EX Environment Zone 1/21 and 2/22

General Housing Data

		TBE 160 TW BACS housing for ATEX Environment	
	Name	TBE 160 TW	
	IECEx & ATEX Zone	Zone 1 / 2 Gas and 21/22 Dust	
	IP Protection Class	IP 66	
	Material	Aluminium, lacquered	
	Cert. According ATEX	18ATEX0119X	
	Cert. According IECEx	DEL 18.0075S	
	Dimensions	300 x 300 x 140mm	
	Operating Temperature	0°-50°C max	
Weight	3.9 KG		

Modules C20

	Atex Zone 1,2/21,22 Housing with M5 Terminal	
	Zone 1, 21:	Order No. C20ex3_Z1_M5
	Zone 2, 22:	Order No. C20ex3_Z2_M5
	Atex Zone 1,2/21,22 Housing with M6 Terminal	
	Zone 1, 21:	Order No. C20ex3_Z1_M6
Zone 2, 22:	Order No. C20ex3_Z2_M6	
Atex Zone 1,2/21,22 Housing with M8 Terminal		
Zone 1, 21:	Order No. C20ex3_Z1_M8	
Zone 2, 22:	Order No. C20ex3_Z2_M8	
Atex Zone 1,2/21,22 Housing with M10 Terminal		
Zone 1, 21:	Order No. C20ex3_Z1_M10Z1	
Zone 2, 22:	Order No. C20ex3_Z2_M10Z1	
Atex Zone 1/21 Housing with M12 Terminal		
Zone 1, 21:	Order No. C20ex3_Z1_M122	
Zone 2, 22:	Order No. C20ex3_Z2_M122	

Modules C30

	Atex Zone 1,2/21,22Housing with M5 Terminal	
	Zone 1, Z21:	Order No. C30ex3_Z1_M5
	Zone 2, Z22:	Order No. C30ex3_Z2_M5
	Atex Zone 1,2/21,22 Housing with M6 Terminal	
	Zone 1, Z21	Order No. C30ex3_Z1_M6
Zone 2, Z22	Order No. C30ex3_Z2_M6	
Atex Zone 1,2/21,22 Housing with M8 Terminal		
Zone 1, Z21	Order No. C30ex3_Z1_M8	
Zone 2, Z22	Order No. C30ex3_Z2_M8	
Atex Zone 1,2/21,22Housing with M10 Terminal		
Zone 1, Z21	Order No. C30ex3_Z1_M10	
Zone 2, Z22	Order No. C30ex3_Z2_M10	
Atex Zone 1,2/21,22Housing with M12 Terminal		
Zone 1, Z21	Order No. C30ex3_Z1_M12	
Zone 2, Z22	Order No. C30ex3_Z2_M12	

Modules C40

	Atex Zone 1,2/21,22Housing with M5 Terminal	
	Z1, Z21	Order No. C40ex3_Z1_M5
	Z2, Z22	Order No. C40ex3_Z2_M5
	Atex Zone 1,2/21,22 Housing with M6 Terminal	
	Zone 1, Z21	Order No. C40ex3_Z1_M6
Zone 2, Z22	Order No. C40ex3_Z2_M6	
Atex Zone 1,2/21,22 Housing with M8 Terminal		
Zone 1, Z21	Order No. C40ex3_Z1_M8	
Zone 2, Z22	Order No. C40ex3_Z2_M8	
Atex Zone 1,2/21,22Housing with M10 Terminal		
Zone 1, Z21	Order No. C40ex3_Z1_M10	
Zone 2, Z22	Order No. C40ex3_Z2_M10	
Atex Zone 1,2/21,22Housing with M12 Terminal		
Zone 1, Z21	Order No. C40ex3_Z1_M12	
Zone 2, Z22	Order No. C40ex3_Z2_M12	



ATEX / IECEx certified BACS® for EX Environment Zone 1/21 and 2/22

BACS ATEX Spare PartsX

These modules are available as spare parts for a BACS ATEX housing.

		<p>Module BACS® C20 Order No. BACSC20 REV 3 module for 12Volt 7-600Ah lead, NiCad, NiMH, Lithium batteries (UL certified)</p>
<p>Voltage range 9.7V – 17V RI range 0.5-60mOhm Equalization power 0.15 A</p>		
		<p>Module BACS® C30 Order No. BACSC30 REV 3 module for 6Volt 7-900Ah lead, NiCad, NiMH, Lithium batteries</p>
<p>Measuring value 4.8V – 8.0V RI range 0.5-60mOhm Equalization power 0.3 A</p>		
		<p>Module BACS® C40 Order No. BACSC40 REV 3 module for 2Volt 7-9000Ah lead, NiCad, NiMH, Lithium batteries (UL certified)</p>
<p>Measuring value 1.2V – 3.2V RI range 0.02-6mOhm Equalization power 0.9 A (at 2.27V)</p>		

BACS Cables

Communication cable to connect ATEX housings with the BACS WEBMANAGER





	<p>BACS® bus cables Order No. B4BCRJx</p>	
	<p>Description Cable coating Contacts Cable length</p>	<p>High quality communication BACS bus communication cable halogen free in accordance with VDE0281 part 14 twisted pair RJ10 Various lengths available. See latest BACS price list for details</p>





ATEX / IECEx certified BACS® for EX Environment Zone 1/21 and 2/22

BACS® CONTROL CABINETS: Technical data and dimensions

Control cabinet for BACS® systems. Plug-play, with AC input plug (Euro) ready to install. With optical and audible display on the outside door, protection class IP 54 with application of included bottom plate. Note that the cabinet is not ATEX certified.

	<p>BACS® CONTROL CABINET Type 1 Order No. BACS_CC1</p>																												
	<table border="0"> <tr><td>Controller</td><td>1</td></tr> <tr><td>Power</td><td>1</td></tr> <tr><td>LAN</td><td>1</td></tr> <tr><td>Contacts</td><td>1</td></tr> <tr><td>Front door</td><td>1</td></tr> <tr><td>Front door</td><td>1</td></tr> <tr><td>Spare parts</td><td>6</td></tr> <tr><td>Dimension</td><td>WHD</td></tr> <tr><td>weight</td><td>kg</td></tr> </table>	Controller	1	Power	1	LAN	1	Contacts	1	Front door	1	Front door	1	Spare parts	6	Dimension	WHD	weight	kg	<table border="0"> <tr><td>BACS WEBMANAGER BUDGET</td></tr> <tr><td>12V Power supply (100 – 240V, 50/60Hz)</td></tr> <tr><td>CAT 6 Ethernet socket</td></tr> <tr><td>Alarm contact (potential-free), 230VC / 30VDC / 8A</td></tr> <tr><td>POWER LED</td></tr> <tr><td>BACS ALARM LED</td></tr> <tr><td>Spare bus communication cable</td></tr> <tr><td>400 x 500 x 210 mm = 15,75 x 19,69 x 8,27 in.</td></tr> <tr><td>16,10</td></tr> </table>	BACS WEBMANAGER BUDGET	12V Power supply (100 – 240V, 50/60Hz)	CAT 6 Ethernet socket	Alarm contact (potential-free), 230VC / 30VDC / 8A	POWER LED	BACS ALARM LED	Spare bus communication cable	400 x 500 x 210 mm = 15,75 x 19,69 x 8,27 in.	16,10
Controller	1																												
Power	1																												
LAN	1																												
Contacts	1																												
Front door	1																												
Front door	1																												
Spare parts	6																												
Dimension	WHD																												
weight	kg																												
BACS WEBMANAGER BUDGET																													
12V Power supply (100 – 240V, 50/60Hz)																													
CAT 6 Ethernet socket																													
Alarm contact (potential-free), 230VC / 30VDC / 8A																													
POWER LED																													
BACS ALARM LED																													
Spare bus communication cable																													
400 x 500 x 210 mm = 15,75 x 19,69 x 8,27 in.																													
16,10																													
	<p>BACS® CONTROL CABINET Type 2 Order No. BACS_CC2</p>																												
	<table border="0"> <tr><td>Controller</td><td>2</td></tr> <tr><td>Power</td><td>2</td></tr> <tr><td>LAN</td><td>2</td></tr> <tr><td>Contacts</td><td>2</td></tr> <tr><td>Front door</td><td>2</td></tr> <tr><td>Front door</td><td>2</td></tr> <tr><td>Spare parts</td><td>8</td></tr> <tr><td>Dimension</td><td>WHD</td></tr> <tr><td>weight</td><td>kg</td></tr> </table>	Controller	2	Power	2	LAN	2	Contacts	2	Front door	2	Front door	2	Spare parts	8	Dimension	WHD	weight	kg	<table border="0"> <tr><td>BACS WEBMANAGER BUDGET</td></tr> <tr><td>12V Power supply (100 – 240V, 50/60Hz)</td></tr> <tr><td>CAT 6 Ethernet socket</td></tr> <tr><td>Alarm contact (potential-free), 230VC / 30VDC / 8A</td></tr> <tr><td>POWER LED</td></tr> <tr><td>BACS ALARM LED</td></tr> <tr><td>spare bus communication cable</td></tr> <tr><td>500 x 500 x 210 mm = 19,69 x 19,69 x 8,27 in.</td></tr> <tr><td>20,20</td></tr> </table>	BACS WEBMANAGER BUDGET	12V Power supply (100 – 240V, 50/60Hz)	CAT 6 Ethernet socket	Alarm contact (potential-free), 230VC / 30VDC / 8A	POWER LED	BACS ALARM LED	spare bus communication cable	500 x 500 x 210 mm = 19,69 x 19,69 x 8,27 in.	20,20
Controller	2																												
Power	2																												
LAN	2																												
Contacts	2																												
Front door	2																												
Front door	2																												
Spare parts	8																												
Dimension	WHD																												
weight	kg																												
BACS WEBMANAGER BUDGET																													
12V Power supply (100 – 240V, 50/60Hz)																													
CAT 6 Ethernet socket																													
Alarm contact (potential-free), 230VC / 30VDC / 8A																													
POWER LED																													
BACS ALARM LED																													
spare bus communication cable																													
500 x 500 x 210 mm = 19,69 x 19,69 x 8,27 in.																													
20,20																													

	<p>BACS® CONTROL CABINET Type 3 Order No. BACS_CC3</p>																												
	<table border="0"> <tr><td>Controller</td><td>3</td></tr> <tr><td>Power</td><td>3</td></tr> <tr><td>LAN</td><td>3</td></tr> <tr><td>Contacts</td><td>3</td></tr> <tr><td>Front door</td><td>3</td></tr> <tr><td>Front door</td><td>3</td></tr> <tr><td>Spare parts</td><td>10</td></tr> <tr><td>Dimension</td><td>WHD</td></tr> <tr><td>weight</td><td>kg</td></tr> </table>	Controller	3	Power	3	LAN	3	Contacts	3	Front door	3	Front door	3	Spare parts	10	Dimension	WHD	weight	kg	<table border="0"> <tr><td>BACS WEBMANAGER BUDGET</td></tr> <tr><td>12V Power supply (100 – 240V, 50/60Hz)</td></tr> <tr><td>CAT 6 Ethernet socket</td></tr> <tr><td>Alarm contact (potential-free), 230VC / 30VDC / 8A</td></tr> <tr><td>POWER LED</td></tr> <tr><td>BACS ALARM LED</td></tr> <tr><td>Spare bus communication cable</td></tr> <tr><td>500 x 500 x 210 mm = 19,69 x 19,69 x 8,27 inch</td></tr> <tr><td>22,70</td></tr> </table>	BACS WEBMANAGER BUDGET	12V Power supply (100 – 240V, 50/60Hz)	CAT 6 Ethernet socket	Alarm contact (potential-free), 230VC / 30VDC / 8A	POWER LED	BACS ALARM LED	Spare bus communication cable	500 x 500 x 210 mm = 19,69 x 19,69 x 8,27 inch	22,70
Controller	3																												
Power	3																												
LAN	3																												
Contacts	3																												
Front door	3																												
Front door	3																												
Spare parts	10																												
Dimension	WHD																												
weight	kg																												
BACS WEBMANAGER BUDGET																													
12V Power supply (100 – 240V, 50/60Hz)																													
CAT 6 Ethernet socket																													
Alarm contact (potential-free), 230VC / 30VDC / 8A																													
POWER LED																													
BACS ALARM LED																													
Spare bus communication cable																													
500 x 500 x 210 mm = 19,69 x 19,69 x 8,27 inch																													
22,70																													

BACS Plus Size BACS Control Cabinets are also available as:

<p>BACS® CONTROL CABINET Type 4 Order No. BACS_CC4</p>	<p>BACS® CONTROL CABINET Type 5 Order No. BACS_CC5</p>	<p>BACS® CONTROL CABINET Type 6 Order No. BACS_CC6</p>
<p>- 4 * BACS WEBMANAGER BUDGET</p>	<p>- 5 * BACS WEBMANAGER BUDGET</p>	<p>- 6 * BACS WEBMANAGER BUDGET</p>
<p>- 4 * 12V Power 100 – 240V, 50/60Hz</p>	<p>- 5 * 12V Power 100 – 240V, 50/60Hz</p>	<p>- 6 * 12V Power 100 – 240V, 50/60Hz</p>
<p>- 4 * CAT 6 Ethernet socket</p>	<p>- 5 * CAT 6 Ethernet socket</p>	<p>- 6 * CAT 6 Ethernet socket</p>



ATEX / IECEx certified BACS® for EX Environment Zone 1/21 and 2/22

- 4 * Alarm contact (potential-free) 230VC, 30VDC, 8A	- 5 * Alarm contact (potential-free) 230VC, 30VDC, 8A	- 6 * Alarm contact (potential-free) 230VC, 30VDC, 8A
- 4 * POWER LED, - 4 * BACS ALARM LED	- 5 * POWER LED, - 5 * BACS ALARM LED	- 6 * POWER LED, - 6 * BACS ALARM LED
12 * spare bus communication cable	14 * spare bus communication cable	16 * spare bus communication cable
- Dimension: 600 x 760 x 210 mm 23,62 x 29,92 x 8,27 in, weight: 38,10 kg	- Dimension: 760 x 760 x 210 mm 29,92 x 29,92 x 8,27 in weight: 48,50 kg	- Dimension: 760 x 760 x 210 mm 29,92 x 29,92 x 8,27 in weight: 55,40 kg

		<p>BACS® CONTROL CABINET with PC All Cabinets are also available with a fully featured Touch Panel Computer</p>
	RAM	1*204-pin SODIMM DDR3L 1333MHz / up to 8GB
	CPU	Intel Bay Trail J1900 Quad Core 2GHz
	Touch Panel	15" XGA TFT multi-point capacitive touch screen
	USB	4* USB Ports and 1 covered USB Service Port
	COM	6 COMPorts
	LAN	2 GLAN P
	Wireless	1 x Mini-PCIe slot, extensible 3G,Wifi wireless card
	Power Consumption (max)	38,6 Watt max
	Input voltage	DC 12V, support reverse polarity protection
	Graphic Software	VGA/HDMI Windows 10 Professional English Language BACS Tools Software packet pre-installed
Operating Condition	-30 ~80°C (-22~176°F)	
Relative humidity	5~95% (Non condensation)	
EMC	CD/FCC Class A	
Notes:	The Operating system is a fully featured Windows 10 operating system and needs additional configuration work. not pre-configured – you need to configure it before first use.	

Also available: BACS Control Cabinet with a full featured Windows Touch Panel All-In-One (AIO) - Computer For

How to order your BAC CC with Touch Panel PC:	
1 BACS WEBMANAGER + PC	BACS_CC1_TP
2 BACS WEBMANAGER + PC	BACS_CC2_TP
3 BACS WEBMANAGER + PC	BACS_CC3_TP
4 BACS WEBMANAGER + PC	BACS_CC4_TP
5 BACS WEBMANAGER + PC	BACS_CC5_TP
6 BACS WEBMANAGER + PC	BACS_CC6_TP